

GAS PRESSURE REGULATORS CATALOG

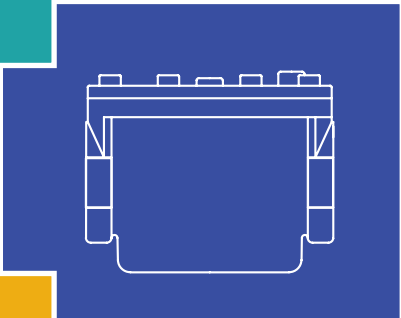
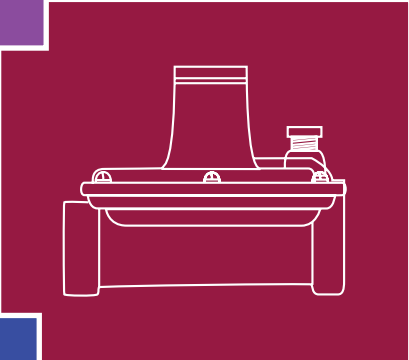
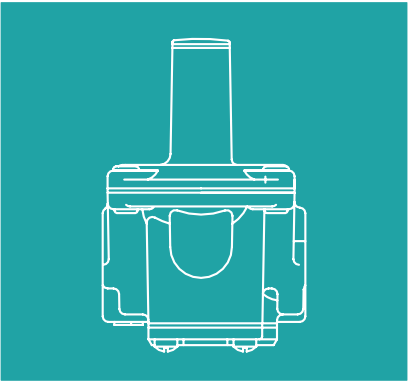
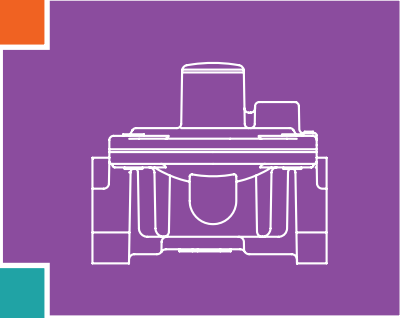
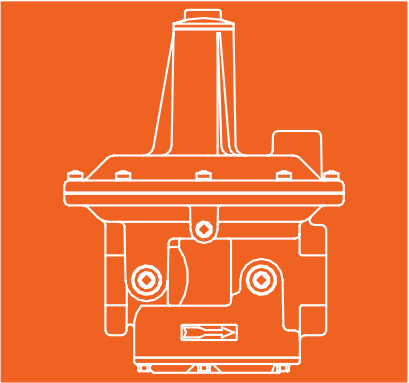

⚠ WARNING

Service and installation must be performed by a trained/experienced service technician.

All products used with combustible gas **must** be installed and used **strictly** in accordance with the instructions of the Original Equipment Manufacturer (OEM) and with all applicable government codes and regulations, e.g. plumbing, mechanical, and electrical codes and practices. Maxitrol products should be installed and operated in accordance with Maxitrol Safety Warning Instructions.

Maxitrol Company is NOT responsible for any errors or omissions in reliance by anyone of any information set forth in this catalog without additional reference to local requirements and applicable ordinances or codes.

Other worldwide approvals and certifications available upon inquiry.



325-L SERIES

Lever Acting Design for 2 psi Piping Systems

Maxitrol's 325-L Series line pressure regulators are for 2 psi piping systems. 325 Series regulators are for use on residential, commercial, and industrial applications.

The 325 Series features a high leverage linkage assembly to deliver positive dead-end lock-up. The regulators are capable of precise regulating control from full flow down to pilot flow.

NOTE: The 325-9L will be available 2Q2014.



325-3L

Specifications

- Pipe Sizes** 3/8" to 2" threaded connections with NPT or ISO7-1 threads.
- Housing Material** 325-3L, 325-5L, 325-7AL, 325-9L: aluminum.
- Mounting** Suitable for multi-positional mounting. If ball check vent limiting device is installed, mount in an upright position only.
NOTE: All Maxitrol gas pressure regulators should be installed and operated in accordance with Maxitrol Safety Warning Instructions (see GPR_CSA_2PSI_MI_EN.FR).
- Certifications** 325-3L, 325-5L, 325-7AL, 325-9L: ANSI Z21.80/CSA 6.22 Line Pressure Regulators.
- Gas Types** Suitable for natural, manufactured, mixed gases, liquefied petroleum gases, and LP gas-air mixtures.
- Maximum Inlet Pressure** 2 psi (13.8 kPa)
- Minimum Inlet Pressure** 1 psi (6.9 kPa)
- Emergency Exposure Limits** 65 psi (450 kPa) (inlet side only)
- Maximum Individual Load** Largest single appliance served by the regulator: 325-3L: 140,000 Btu/h; 325-5L: 425,000 Btu/h; 325-7AL: 1,250,000 Btu/h; 325-9L: 2,250,000 Btu/h
- Capacity** Total load of multiple appliance combined
325-3L (3/8", 1/2"): 250,000 Btu/h;
325-5L (1/2"): 500,000 Btu/h; 325-5L (3/4", 1"): 600,000 Btu/h;
325-7AL (1 1/4", 1 1/2"): 1,250,000 Btu/h; 325-9L (1 1/2", 2"): 2,250,000 Btu/h
NOTE: Capacities are used to determine the maximum multiple appliance load. The largest single appliance served by the regulator should not exceed the maximum individual load specified above.
- Ambient Temperature Ranges** -40 to 205°F (-40 to 96°C)
- Minimum Regulation** Suitable for pilot flow applications. \textcircled{P} (Circle P) (0.15 CFH NG), ∇ (Delta P) (0.50 CFH NG).
- Imblue Technology™** 325-3L, 325-5L, 325-7AL, 325-9L models may be ordered with Imblue Technology™. Imblue Technology™ increases corrosion resistance and provides extra protection against the elements for regulators used in outdoor applications. Add suffix letter "B" to model number when ordering.



Capacities

Capacities expressed in CFH (m³/h) @ 0.64 sp gr gas

Model	Pipe Size	Outlet Pressure Set Point	Operating Inlet Pressure				
			1/2 psi (3.4 kPa)	3/4 psi (5.2 kPa)	1 psi (6.9 kPa)	1 1/2 psi (10.3 kPa)	2 psi (13.8 kPa)
325-3L	3/8" x 3/8" 1/2" x 1/2"	7.0" w.c. (1.7 kPa)	145 (4.1)	200 (5.7)	250 (7.1)	250 (7.1)	250 (7.1)
		10.0" w.c. (2.5 kPa)	110 (3.1)	180 (5.1)	230 (6.5)	250 (7.1)	250 (7.1)
325-5L	1/2" x 1/2"	7.0" w.c. (1.7 kPa)	360 (10.2)	485 (13.7)	500 (14.2)	500 (14.2)	500 (14.2)
		10.0" w.c. (2.5 kPa)	275 (7.8)	475 (13.5)	500 (14.2)	500 (14.2)	500 (14.2)
325-5L	3/4" x 3/4" 1" x 1"	7.0" w.c. (1.7 kPa)	370 (10.5)	520 (14.7)	600 (17.0)	600 (17.0)	600 (17.0)
		10.0" w.c. (2.5 kPa)	275 (7.8)	450 (12.7)	570 (16.1)	600 (17.0)	600 (17.0)
325-7AL	1 1/4" x 1 1/4" 1 1/2" x 1 1/2"	7.0" w.c. (1.7 kPa)	750 (21.2)	1000 (28.3)	1250 (35.4)	1250 (35.4)	1250 (35.4)
		10.0" w.c. (2.5 kPa)	525 (14.9)	900 (25.5)	1125 (31.9)	1250 (35.4)	1250 (35.4)
325-9L	1 1/2" x 1 1/2" 2" x 2"	7.0" w.c. (1.7 kPa)	1390 (39.4)	2080 (58.9)	2250 (63.7)	2250 (63.7)	2250 (63.7)
		10.0" w.c. (2.5 kPa)	1050 (29.7)	1660 (47.0)	2090 (59.2)	2250 (63.7)	2250 (63.7)

NOTE: See pages 58-59 for Regulator Sizing Requirements and Examples.

Pressure Drop: expressed in CFH (m³/h) @ 0.64 sp gr gas

Model Number	7.0" w.c. (1.7 kPa)	1/2 psi (3.4 kPa)	3/4 psi (5 kPa)
325-3L	145 (4.0)	204 (5.8)	250 (7.0)
325-5L	400 (11.3)	550 (15.6)	670 (19.0)
325-7AL	815 (23.1)	1149 (32.5)	1405 (39.8)
325-9L	1360 (38.5)	2113 (59.8)	2557 (72.4)

Spring Selection

Outlet Pressure Range (all models)

Certified Spring 7" to 11" w.c. (1.7 to 2.7 kPa)

NOTE: See to pages 56-57 for complete Spring Selection Chart.

325-L SERIES

Lever Acting Design for 2 psi Piping Systems

Dimensions

Model	Pipe Size	Vent Connection	Swing Radius	Dimensions		
				A	B	C
325-3L	3/8", 1/2"	1/8" NPT	3" (76 mm)	3.5" (89 mm)	4.2" (108 mm)	3.9" (98 mm)
325-5L	1/2", 3/4", 1"	3/8" NPT	4.9" (124 mm)	5.3" (133 mm)	5.9" (149 mm)	5.4" (138 mm)
325-7AL	1 1/4", 1 1/2"	1/2" NPT	6.1" (156 mm)	7.3" (184 mm)	8" (203 mm)	7" (178 mm)
325-9L	1 1/2", 2"	1/2" NPT	7.8" (198 mm)	9.4" (239 mm)	10.8" (274 mm)	9.1" (231 mm)

NOTE: Dimensions are maximums and to be used only as an aid in designing clearance for the valve.
Actual production dimensions may vary somewhat from those shown.

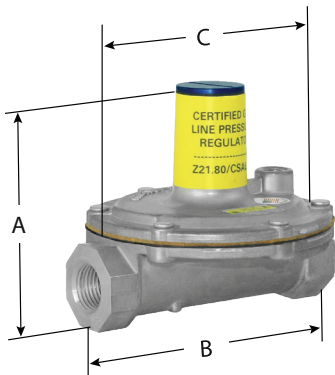

325-3L

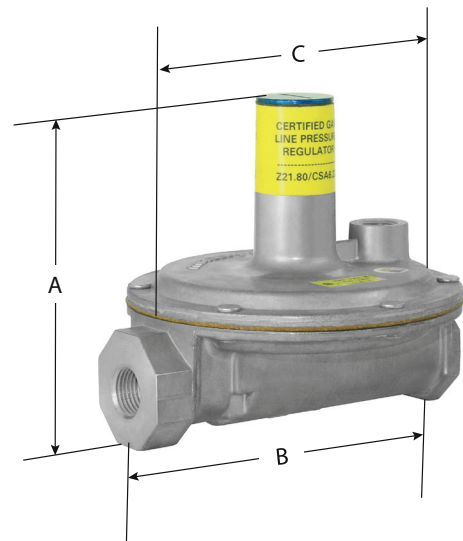

325-5L

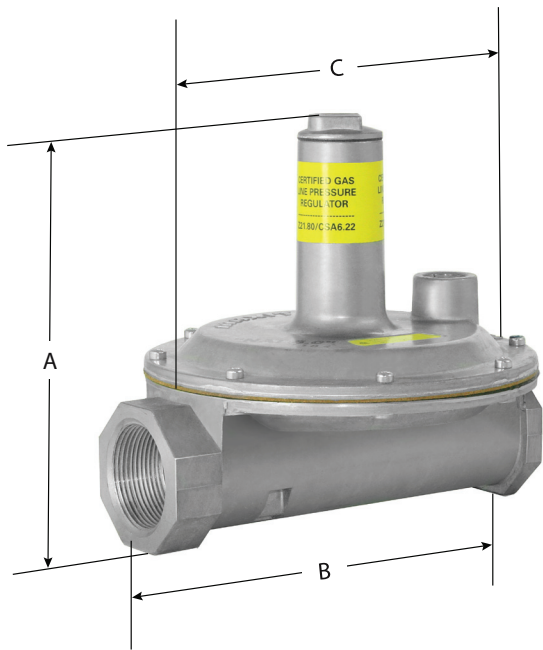

325-7AL

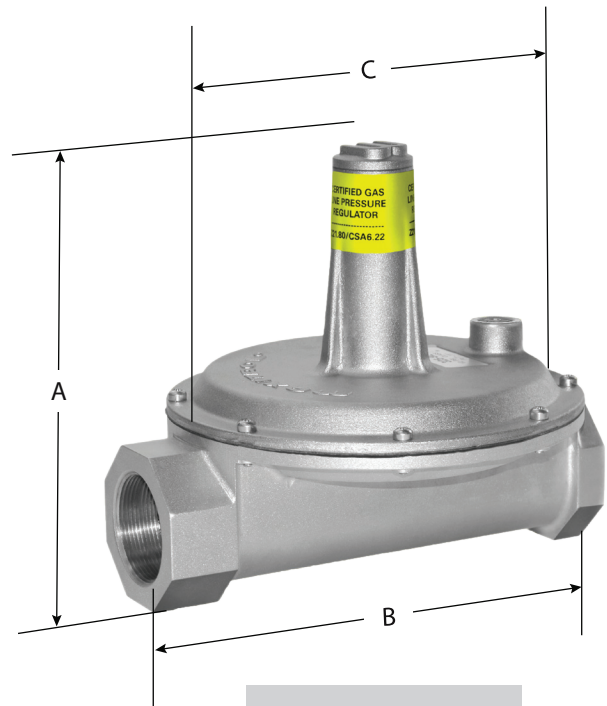

325-9L

Lever Acting Design

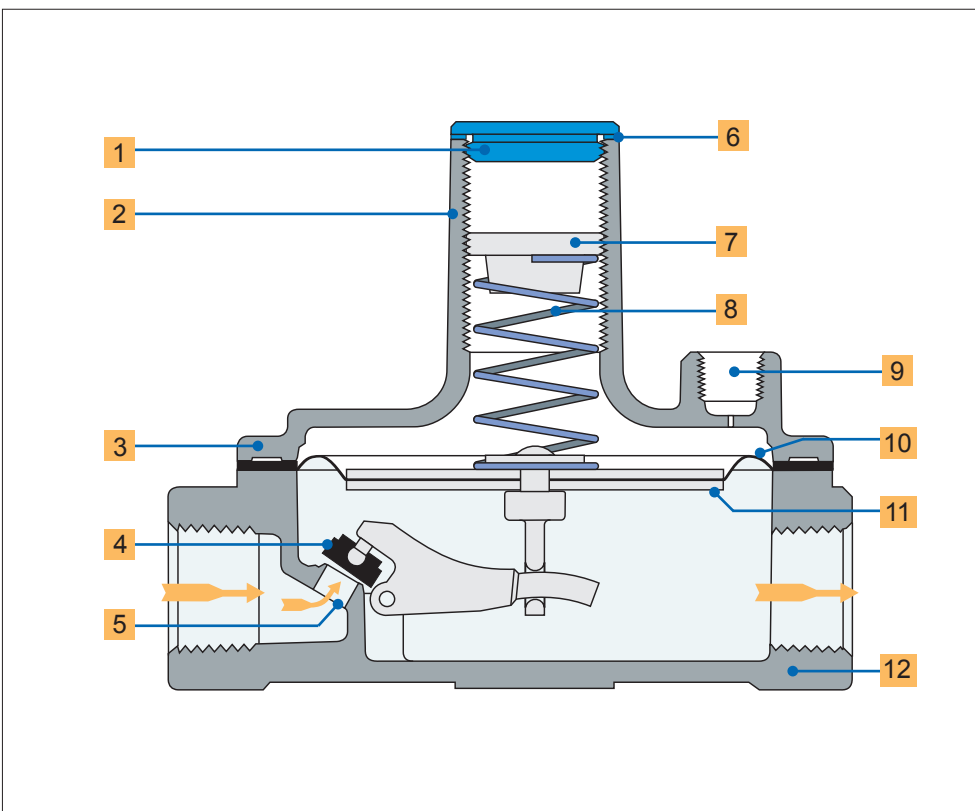

- 1 Seal Cap
- 2 Stack
- 3 Top Housing
- 4 Rubber Valve
- 5 Valve Seat
- 6 Seal Cap Gasket
- 7 Adjusting Screw
- 8 Spring
- 9 Vent Connection
- 10 Diaphragm
- 11 Diaphragm Plates
- 12 Bottom Housing

NOTE: Diagrams are graphical representations only and may differ from actual product.

